

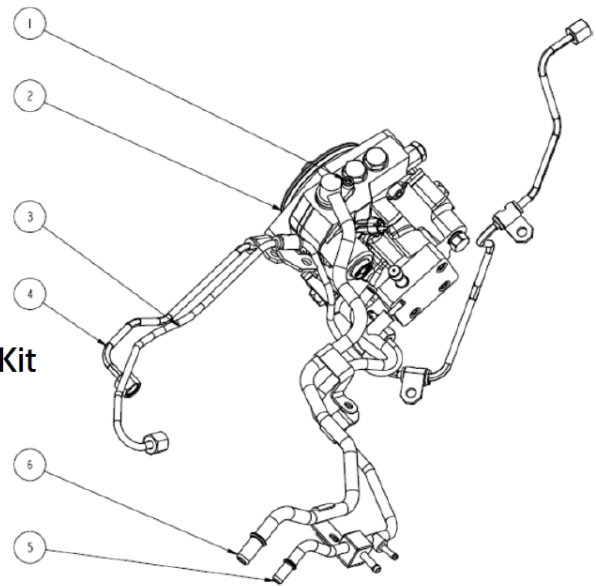

INSTALLATION INSTRUCTIONS:

Duramax L5P 2017-2023 DCR Pump Conversion Kit

PART: DDPL5P-DCRKIT



6	609263	1	FUEL TUBE ASSY., LP-SUPPLY	
5	609254	1	FUEL TUBE ASSY., LP-RETURN	
4	609167	1	FUEL TUBE ASSY., HP-RAIL	
3	609166	1	FUEL TUBE ASSY., HP-PUMP	
2	608800	1	CR PUMP, ASSEMBLY (CW)	
1	46162	1	SCREW, SOCKET HEAD CAP	
ITEM	PART NUMBER	QTY	DESCRIPTION	NOTES

Torque Values

Fastener	Standard	Metric (Nm)	Notes
Air Cleaner Resonator Nut	16 lb ft	22	
EGR Valve Pipe Heat Shield Bolt	80 lb in	9	
EGR Pipe Bolt	27 lb ft	36	
Engine Coolant Fan Bracket Bolt	16 lb ft	22	
Engine Coolant Fan Clutch Nut	74 lb ft	100	Left Hand Thread
Drive Belt Tensioner Bolt	43 lb ft	58	
Glow Plug Control Module Bolt	89 lb in	10	
Alternator Mounting Bolt	43 lb ft	58	Single and Dual Alternator (If equipped)
Alternator Bracket Bolt	37 lb ft	50	
Alternator Bracket Nut	37 lb ft	50	
Fan Pulley Nut	18 lb ft	25	
Fan Pulley Bolt (M10)	37 lb ft	50	
Fan Pulley Bolt (M8)	18 lb ft	25	
Air Conditioning Compressor Bolt	43 lb ft	58	
Power Steering Pump Bolt	16 lb ft	22	
Air Conditioning Compressor Bracket Bolt	37 lb ft	50	
Air Conditioning Compressor Bracket Nut	37 lb ft	50	
Thermostat Bypass Pipe Bolt	18 lb ft	25	
Turbocharger Air Inlet Adapter Bolt	18 lb ft	25	
Upper Intake Manifold Bolt	89 lb in	10	Follow Torque Sequence
EGR Valve Manifold Cooling Return Pipe Bolt	89 lb in	10	
Fuel Feed and Return Pipe Bolt	89 lb in	10	
High Pressure Fuel Line Bracket Bolt	89 lb in	10	
High Pressure Fuel Line Nut	24 lb ft	32.5	
EGR Manifold Cooling Feed Pipe Bolt	89 lb in	10	
Engine Coolant Thermostat Housing Bolt	18 lb ft	25	Follow Torque Sequence
Engine Coolant Thermostat Housing Nut	18 lb ft	25	Follow Torque Sequence
Fuel Pump adapter bolt (Through timing cover)	18 lb ft	25	Bottom two pump adapters retaining bolts
Fuel Pump adapter bolt (Through engine block)	15 lb ft	21	Top two pump adapters retaining bolts
Fuel Injection Pump Nut	48 lb ft	65	

2. Required tools

- a. Assorted hand tools – Sockets, ratchets, wrenches, pliers, screwdrivers, etc.
- b. 17mm Crows foot or line wrench socket – High pressure fuel line tightening
- c. Torque wrench(es)
 - i. 80-89 lb in range (9-10 Nm)
 - ii. 16-74 lb ft range (22-100 Nm)
- d. Fan clutch tools – 52mm wrench and pulley holder
- e. Serpentine belt tensioner tools
- f. Fuel line quick disconnect tool – 3/8” and 1/2”
- g. Fuel pump gear holding tool – GM EN-51142 or similar
- h. Pin punch - gasket retaining pin removal
- i. Stand up creeper or step(s) will make engine work much easier

3. GM replacement part numbers

High Pressure Pump Drive Gear - 12698076
Engine Coolant Thermostat Housing Gasket – 2x 12643149
EGR Coolant Feed Pipe Gasket - 12648140
EGR Pipe Gasket - 12680216
Thermostat Bypass Pipe Gasket - 12737097
Thermostat Bypass Pipe Seal - 12658352
Turbocharger Air Inlet Adapter Seal - 12651147
Upper Intake Manifold Seal – 2x 12642410
Fan shroud retainers – 4x 11589296, 2x 01605396 – only needed if damaged/lost
High pressure fuel pump supply/return tube assembly – 12729812 – only needed if hoses damaged

4. Parts Removal

- a) Disconnect batteries, starting with the secondary (passenger side) battery first
- b) Drain coolant – drain is on passenger side, bottom of radiator. **It is not necessary to drain the coolant from the smaller coolant tank which is for the aftertreatment system**
- c) Remove 10mm air cleaner nut at fender, disconnect MAF sensor, clamp at turbo and 13mm nut near air conditioning compressor. Remove air filter housing and tube as an assembly
- d) Remove upper radiator hose – spring clamp at thermostat housing and 8mm hose clamp at radiator
- e) Remove six plastic push retainers and unclip AC hoses from upper fan shroud and remove upper fan shroud
- f) Disconnect cooling fan connector, remove fan harness retainer from ball stud and using suitable fan clutch wrench (52mm) and pulley holder, remove cooling fan. **FAN CLUTCH IS LEFT HAND THREAD**
- g) Remove four 13mm fan bracket bolts and remove bracket
- h) Relieve tension on belts with an appropriate tool and remove fan drive belt and accessory drive belt.
Taking a picture of the drive belt routing is recommended
- i) If equipped with dual alternators, remove electrical connections on driver’s side alternator, 15mm alternator bolts and remove alternator
- j) Remove two 13mm nuts from studs at the Air Conditioning compressor. Set bracket with wiring harness connector aside
- k) Remove four 15mm bolts for AC compressor and set AC compressor to the side, on passenger side battery. Ensure that batteries are disconnected, and compressor is not touching the battery terminals
- l) Disconnect intake air temperature sensor at throttle body inlet, and clip at throttle body inlet hose. Position hose aside
- m) Remove 10mm bolts for glow plug control module from alternator bracket and position aside
- n) Remove 10mm bolt from alternator bracket for heater tube
- o) Disconnect nut at alternator and electrical connection from alternator. Remove two 15mm bolts and remove alternator

- p) Remove 15mm bolts for accessory belt tensioner and idler pulley behind fan drive hub. Remove tensioner and pulley
- q) Remove the 15mm bolt and two 15mm nuts on alternator bracket and remove bracket. Remove three wiring harness clips at the bottom/rear/underside of bracket
- r) Remove two 15mm bolts, one 13mm bolt and two 13mm nuts on fan bracket and remove fan bracket
- s) Remove wiring bracket/Power Steering hose support on backside of PS by removing two 10mm bolts at bracket and one 10mm bolt at PS hose
- t) Remove Three 13mm bolts through front of PS pump pulley, and one from rear of PS pump bracket. Remove the power steering pump from bracket and position aside with hoses connected
- u) Remove two 15mm nuts and one 15mm bolt from PS bracket and remove bracket
- v) Disconnect coolant temperature sensor connector at the thermostat housing and spring clamp from hose at backside of thermostat housing
- w) Remove 13mm bolt at EGR coolant return at the thermostat housing and two 13mm bolts for the thermostat bypass tube at the water pump
- x) Remove 10mm bolts from EGR coolant return at the EGR cooler. Removing the tube is not necessary and can be positioned aside
- y) Remove 10mm bolts at EGR cooler coolant supply
- z) Remove 13mm - bolts (4x) and nuts (4x) from thermostat housing at cylinder head, and remove thermostat housing
- aa) Remove 13mm bolts at turbocharger inlet adapter and set aside. **Note: it is not possible to remove the inlet adapter without cutting hose clamps and damaging hose between inlet adapter and the positive crankcase ventilation oil separator – this piece is not available separately. Avoid damaging this tube/hose**
- bb) Remove three 10mm EGR tube heat shield bolts and remove EGR heat shield
- cc) Remove two 13mm EGR bolts at the upper intake behind throttle body
- dd) Disconnect MAP/IAT sensor, throttle body electrical connector, two wiring harness connectors and all the wiring harness clips for the wiring harness at the upper intake. **Take note of wiring harness routing – reinstalling all the clips and properly routing the harness will prevent future issues**
- ee) Remove eight 10mm bolts for the upper intake and two 10mm bolts for the coolant vent line. Position coolant vent line aside and remove upper intake. **Best practice would be to cover the two intake ports of the lower intake manifold to ensure that no tools or hardware is dropped into the engine. Serious engine damage can occur**
- ff) Remove the 10mm bolts holding the passenger injector return line and both high pressure lines. Loosen the two high pressure fuel line tube nuts from the rail to pump and rail to rail and remove the high-pressure fuel lines. **Best practice would be to cover the rail fittings to ensure that no dirt or debris enters the fuel system**
- gg) Gently pry the locking tab up on the fuel supply line to pump and disconnect fitting
- hh) Release hose clamps from fuel return elbow and remove elbow. This hose and clamps will be reused with the new return line assembly. **Do not discard or damage hose**
- ii) Remove the tube retaining bolt and disconnect passenger side injector fuel return hose from return tube. This hose will be reused with the new return line assembly. **Do not discard or damage hose**
- jj) Remove the 13mm bolts that hold the pump adapter onto the engine block. Two passes through the timing cover and two pass through the engine block.
- kk) Disconnect electrical connector at pump.
- ll) Gently slide the pump back from the engine.
- mm) Rotate pump up so gear is facing up and remove pump.
- nn) Loosen 11mm nut on turbo compressor discharge hose clamp and slide hose from turbo.
- oo) Position tube aside.
- pp) Remove two 10mm bolts on fuel supply/return hose assembly.
- qq) Place a towel/rag/absorbent mat underneath the two fuel quick connect fittings over the valve cover to catch any spilled fuel.
- rr) Remove locking clips from supply and return hoses.
- ss) Using the appropriate quick disconnect tool, disconnect the supply and return hose.

- tt) Disconnect the injector return hose and rail return hose from the return tube. These hoses will be reused with the new return line assembly. **Do not discard or damage hoses.**
- uu) Remove the fuel supply/return tube assembly.

5. Reinstallation

- a. Clean engine block at high pressure fuel pump mounting plate. The area should be free from dirt, rust and debris.
- b. Clean engine valley for any spilled fuel or coolant.

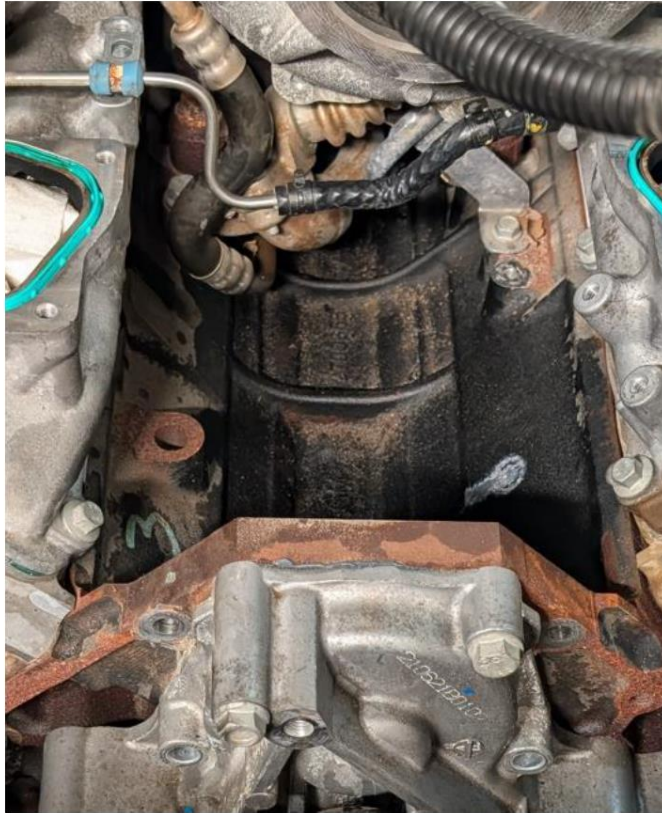

- c. On a work bench, using the EN-51142 pump gear holding tool or similar, remove the gear holding nut from the pump. **DO NOT REUSE PUMP DRIVE GEAR**



- d. Install a **NEW** pump drive gear onto the DCR pump and torque to 48 lb ft (65 Nm) using the gear holding tool and the used nut from the previous step. **Note: the DCR pump has no key and is normal. Timing the pump to the engine is not required**



- e. Place return line into engine valley loosely in position. Supply line and bolts will be installed later
- f. Lubricate O-ring on pump mounting plate with engine oil
- g. Install pump on engine by positioning pump into valley with gear facing up and rotate down and forward into engine block
- h. Push pump into engine block by hand, do not pry on pump, and do not use bolts to pull pump into position



- i. Tighten bolts by hand, snug bolts alternating from side to side and top to bottom
- j. Torque upper two bolts (through engine block) to 15 lb ft (21 Nm) and lower two (through timing cover) to 18 lb ft (25 Nm)
- k. Loosely install rail to rail and pump to rail high pressure lines, finger tighten tube nuts to rail(s)/pump and loosely install line retaining bolts
- l. Torque high pressure line tube nuts to 24 lb ft (32.5 Nm)
- m. Tighten line retaining bolts
- n. Install passenger injector return hose to the return tube and elbow removed in step **hh** from rear of pump to new return line assembly
- o. Install retaining bolt for passenger side injector return

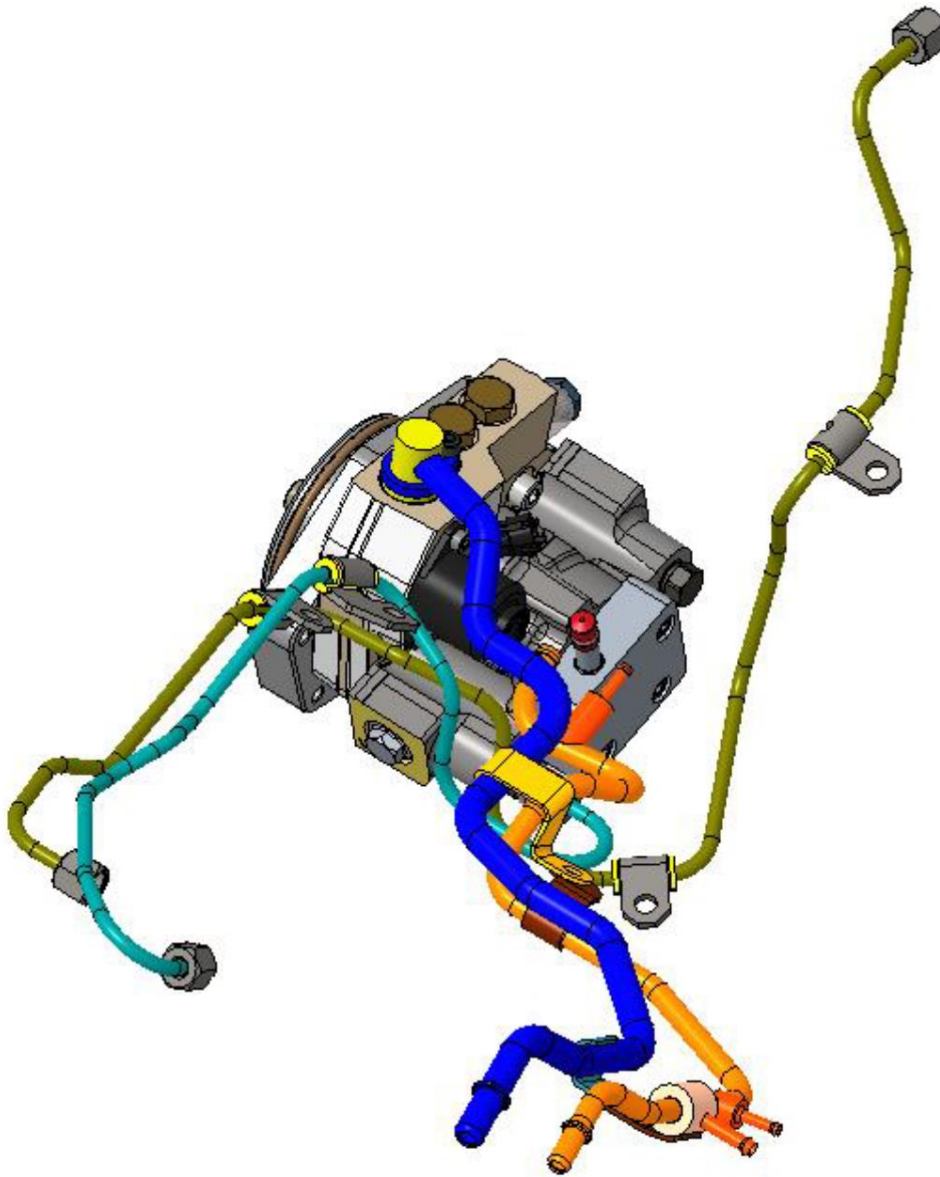

- p. Lubricate fuel supply tube O-rings and loosely install fuel supply tube to pump/engine
- q. Gently push supply tube into pump and loosely install the supplied retaining bolt at pump
- r. Loosely install the supply/return tube retaining bolts, with the supply tube brackets on the top of the return
- s. Tighten supply tube retaining bolt to pump to 89 lb in (10 Nm)
- t. Tighten supply/return tube retaining bolts

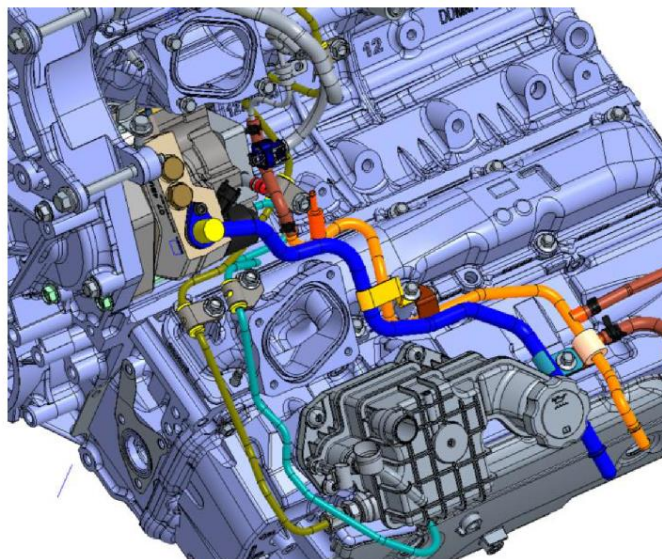

- u. Reconnect electrical connector at pump – Inlet Metering Valve in different position on pump, but reuses OE connector and wiring, no adapter/extension needed



- v. Replace gaskets disturbed during removal. Note: some gaskets are retained with pins in the flange that will need to be removed with a pin punch. The pins can be reused, but not required, only aids in alignment and reinstallation
- w. Reverse the removal steps to complete installation, paying attention to these two tightening sequences:
 - i. Upper intake manifold tightening sequence

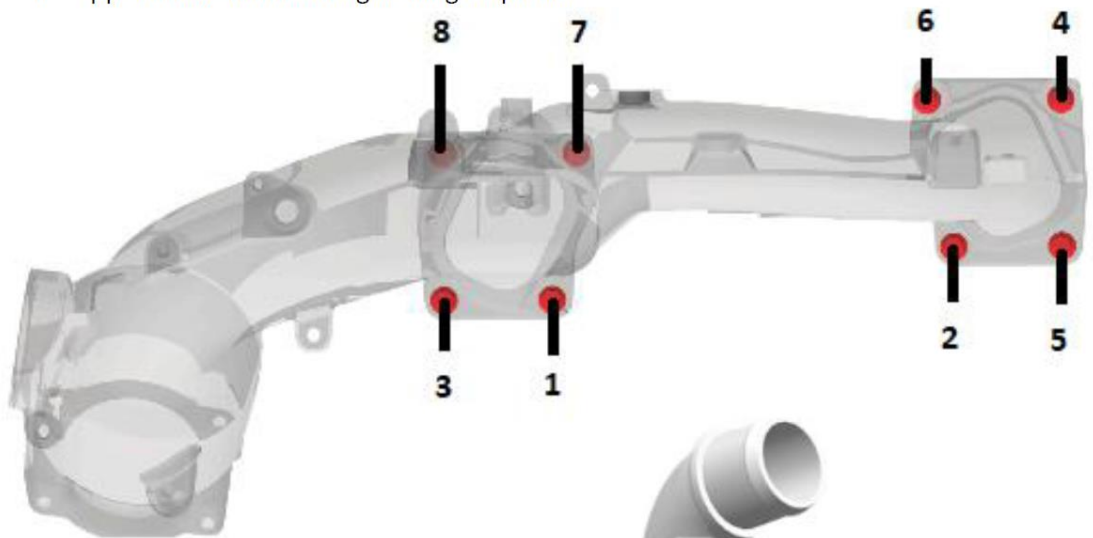

- ii. Thermostat housing tightening sequence

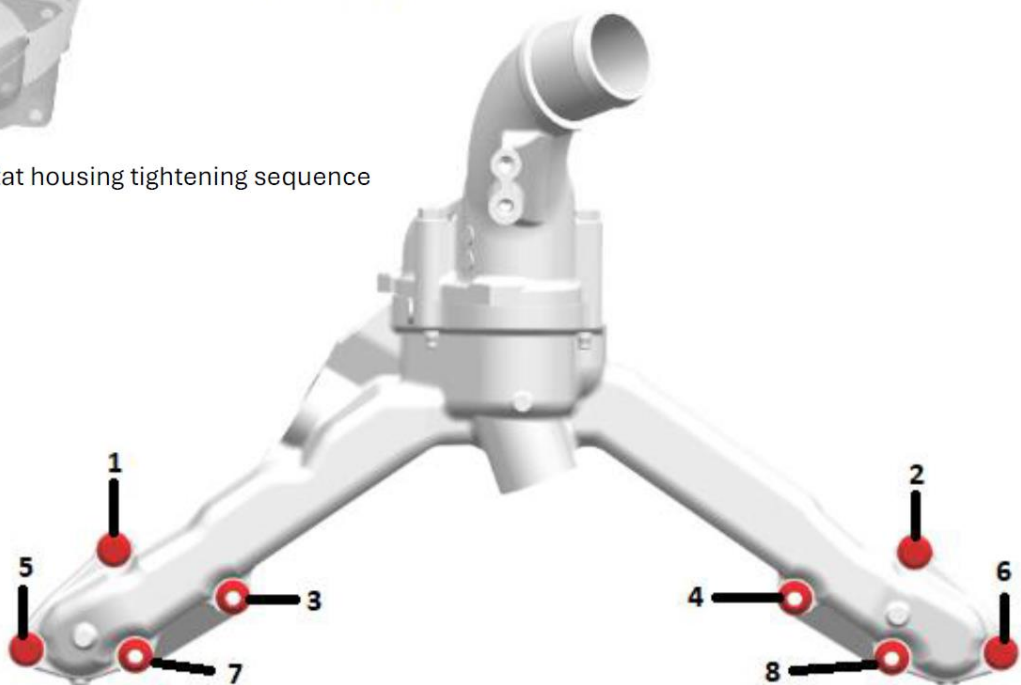

6. Start-Up

- a. Refill cooling system
- b. Reconnect batteries, starting with the primary battery (Driver's side) and then secondary battery (Passenger)
- c. **Prime fuel system.** Key on (press start button with foot off brake pedal if not equipped with a key) until electric fuel pump stops and then off for 30 seconds. **Repeat for a total of five times.**
- d. After fuel system priming start engine and check for leaks – fuel, high and low pressure and coolant

